

# BTN7960

High Current PN Half Bridge  
NovalithIC™

Automotive Power



Never stop thinking

## Table of Contents

<b>1</b>	<b>Overview</b>	<b>3</b>
<b>2</b>	<b>Block Diagram</b>	<b>4</b>
2.1	Block Diagram	4
2.2	Terms	4
<b>3</b>	<b>Pin Configuration</b>	<b>5</b>
3.1	Pin Assignment	5
3.2	Pin Definitions and Functions	5
<b>4</b>	<b>General Product Characteristics</b>	<b>6</b>
4.1	Absolute Maximum Ratings	6
4.2	Functional Range	8
4.3	Thermal Resistance	8
<b>5</b>	<b>Block Description and Characteristics</b>	<b>9</b>
5.1	Supply Characteristics	9
5.2	Power Stages	10
5.2.1	Power Stages - Static Characteristics	11
5.2.2	Switching Times	12
5.2.3	Power Stages - Dynamic Characteristics	13
5.3	Protection Functions	15
5.3.1	Overvoltage Lock Out	15
5.3.2	Undervoltage Shut Down	15
5.3.3	Overtemperature Protection	15
5.3.4	Current Limitation	15
5.3.5	Short Circuit Protection	17
5.3.6	Electrical Characteristics - Protection Functions	18
5.4	Control and Diagnostics	19
5.4.1	Input Circuit	19
5.4.2	Dead Time Generation	19
5.4.3	Adjustable Slew Rate	19
5.4.4	Status Flag Diagnosis With Current Sense Capability	19
5.4.5	Truth Table	20
5.4.6	Electrical Characteristics - Control and Diagnostics	21
<b>6</b>	<b>Application Information</b>	<b>22</b>
6.1	Application Example	22
6.2	Layout Considerations	22
6.3	Half-bridge Configuration Considerations	23
<b>7</b>	<b>Package Outlines</b>	<b>24</b>
7.1	PG-TO263-7-1	24
7.2	PG-TO220-7-11	25
7.3	PG-TO220-7-12	26
<b>8</b>	<b>Revision History</b>	<b>27</b>

## High Current PN Half Bridge NovalithIC™

**BTN7960B**  
**BTN7960P**  
**BTN7960S**



### 1 Overview

#### Features

- Path resistance of max. 30.5 mΩ @ 150 °C (typ. 16 mΩ @ 25 °C)  
High Side: max. 12.8 mΩ @ 150 °C (typ. 7 mΩ @ 25 °C)  
Low Side: max. 17.7 mΩ @ 150 °C (typ. 9 mΩ @ 25 °C)  
(for BTN7960B (SMD))
- Low quiescent current of typ. 7 μA @ 25 °C
- PWM capability of up to 25 kHz combined with active freewheeling
- Switched mode current limitation for reduced power dissipation in overcurrent
- Current limitation level of 33 A min. / 47 A typ. (low side)
- Status flag diagnosis with current sense capability
- Overtemperature shut down with latch behaviour
- Overvoltage lock out
- Undervoltage shut down
- Driver circuit with logic level inputs
- Adjustable slew rates for optimized EMI
- Green Product (RoHS compliant)
- AEC Qualified

#### Description

The BTN7960 is a integrated high current half bridge for motor drive applications. It is part of the NovalithIC™ family containing one p-channel highside MOSFET and one n-channel lowside MOSFET with an integrated driver IC in one package. Due to the p-channel highside switch the need for a charge pump is eliminated thus minimizing EMI. Interfacing to a microcontroller is made easy by the integrated driver IC which features logic level inputs, diagnosis with current sense, slew rate adjustment, dead time generation and protection against over-temperature, overvoltage, undervoltage, overcurrent and short circuit.

The BTN7960 provides a cost optimized solution for protected high current PWM motor drives with very low board space consumption.

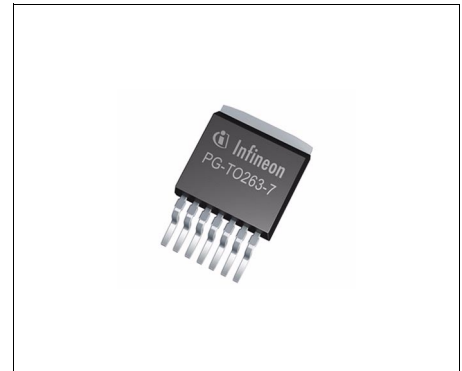

PG-TO263-7-1

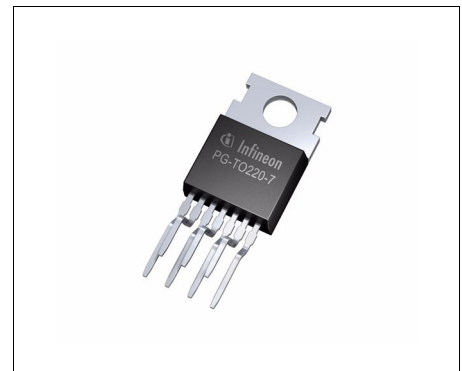

PG-TO220-7-11

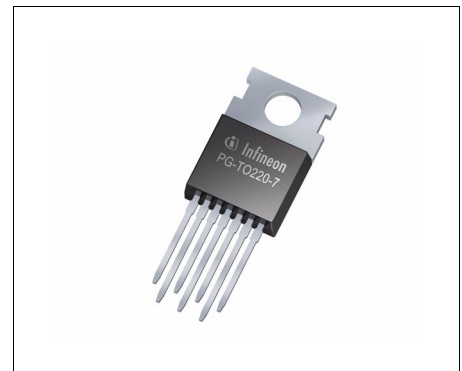

PG-TO220-7-12

Type	Package	Marking
BTN7960B	PG-TO263-7-1	BTN7960B
BTN7960P	PG-TO220-7-11	BTN7960P
BTN7960S	PG-TO220-7-12	BTN7960S

## 2 Block Diagram

The BTN7960 is part of the NovalithIC™ family containing three separate chips in one package: One p-channel highside MOSFET and one n-channel lowside MOSFET together with a driver IC, forming an integrated high current half-bridge. All three chips are mounted on one common lead frame, using the chip on chip and chip by chip technology. The power switches utilize vertical MOS technologies to ensure optimum on state resistance. Due to the p-channel highside switch the need for a charge pump is eliminated thus minimizing EMI. Interfacing to a microcontroller is made easy by the integrated driver IC which features logic level inputs, diagnosis with current sense, slew rate adjustment, dead time generation and protection against overtemperature, overvoltage, undervoltage, overcurrent and short circuit. The BTN7960 can be combined with other BTN7960 to form H-bridge and 3-phase drive configurations.

### 2.1 Block Diagram

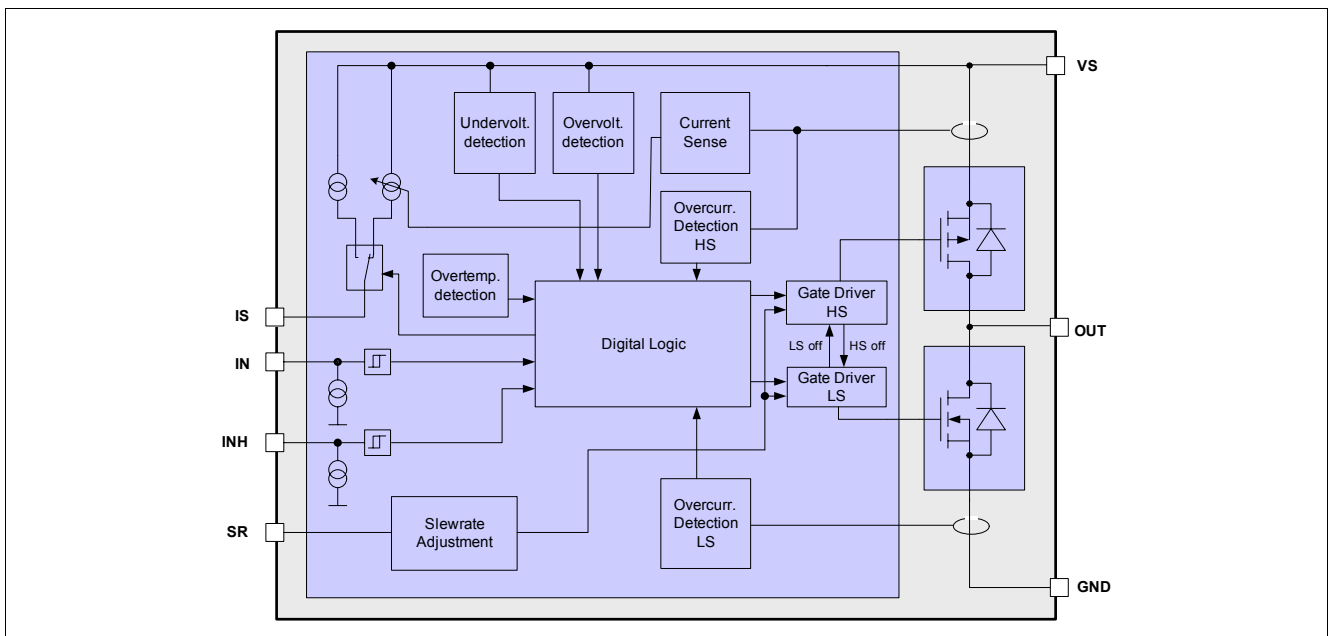

Figure 1 Block Diagram

### 2.2 Terms

Following figure shows the terms used in this data sheet.

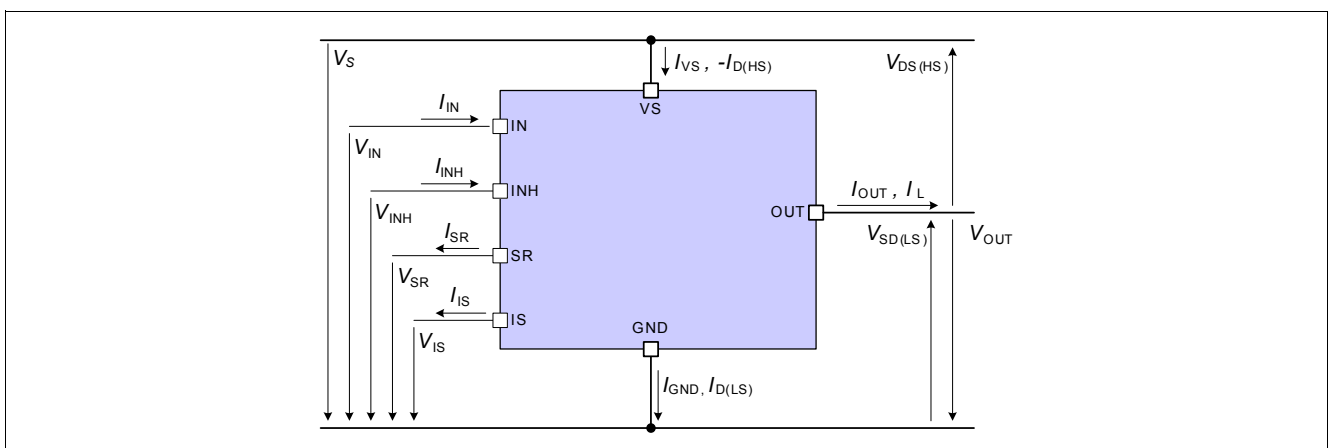

Figure 2 Terms

### 3 Pin Configuration

#### 3.1 Pin Assignment

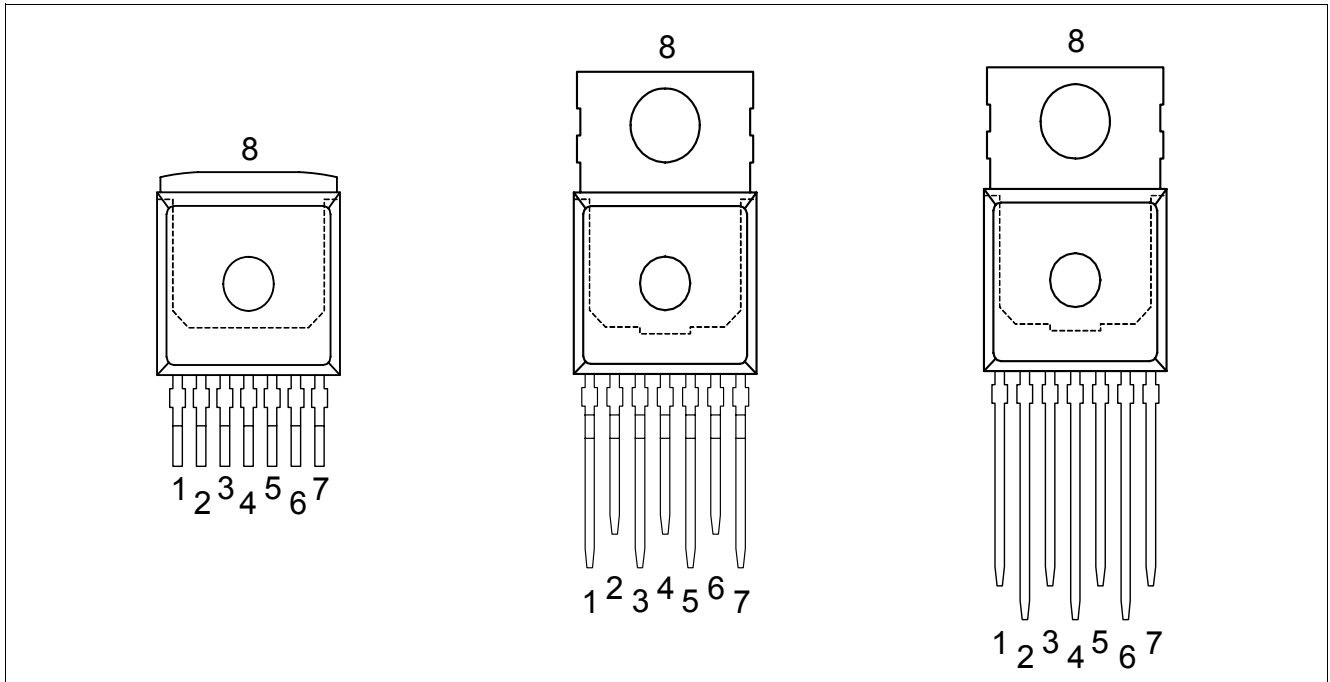

Figure 3 Pin Assignment BTN7960B, BTN7960P and BTN7960S (top view)

#### 3.2 Pin Definitions and Functions

Pin	Symbol	I/O	Function
1	<b>GND</b>	-	<b>Ground</b>
2	IN	I	Input Defines whether high- or lowside switch is activated
3	INH	I	Inhibit When set to low device goes in sleep mode
<b>4,8</b>	<b>OUT</b>	<b>O</b>	<b>Power output of the bridge</b>
5	SR	I	Slew Rate The slew rate of the power switches can be adjusted by connecting a resistor between SR and GND
6	IS	O	Current Sense and Diagnostics
7	<b>VS</b>	-	<b>Supply</b>

**Bold type: pin needs power wiring**

## 4 General Product Characteristics

### 4.1 Absolute Maximum Ratings

#### Absolute Maximum Ratings <sup>1)</sup>

$T_j = -40\text{ °C}$  to  $+150\text{ °C}$ ; all voltages with respect to ground, positive current flowing into pin (unless otherwise specified)

Pos.	Parameter	Symbol	Limit Values		Unit	Conditions
			Min.	Max.		
<b>Voltages</b>						
4.1.1	Supply Voltage	$V_S$	-0.3	45	V	–
4.1.2	Logic Input Voltage	$V_{IN}$ $V_{INH}$	-0.3	5.3	V	–
4.1.3	Voltage at SR Pin	$V_{SR}$	-0.3	1.0	V	–
4.1.4	Voltage between VS and IS Pin	$V_S - V_{IS}$	-0.3	45	V	–
4.1.5	Voltage at IS Pin	$V_{IS}$	-20	45	V	–
<b>Currents</b>						
4.1.6	HS/LS Continuous Drain Current <sup>2)</sup>	$I_{D(HS)}$ $I_{D(LS)}$	-44	44	A	$T_C < 85\text{ °C}$ switch active
			-40	40	A	$T_C < 125\text{ °C}$ switch active
4.1.7	HS/LS Pulsed Drain Current <sup>2)</sup>	$I_{D(HS)}$ $I_{D(LS)}$	-90	90	A	$T_C < 85\text{ °C}$ $t_{pulse} = 10\text{ms}$ single pulse
			-85	85	A	$T_C < 125\text{ °C}$ $t_{pulse} = 10\text{ms}$ single pulse
4.1.8	HS/LS PWM Current <sup>2)</sup>	$I_{D(HS)}$ $I_{D(LS)}$	-55	55	A	$T_C < 85\text{ °C}$ $f = 1\text{kHz}$ , DC = 50%
			-50	50	A	$T_C < 125\text{ °C}$ $f = 1\text{kHz}$ , DC = 50%
			-60	60	A	$T_C < 85\text{ °C}$ $f = 20\text{kHz}$ , DC = 50%
			-54	54	A	$T_C < 125\text{ °C}$ $f = 20\text{kHz}$ , DC = 50%
<b>Temperatures</b>						
4.1.9	Junction Temperature	$T_j$	-40	150	°C	–
4.1.10	Storage Temperature	$T_{stg}$	-55	150	°C	–
<b>ESD Susceptibility</b>						
4.1.11	ESD Susceptibility HBM IN, INH, SR, IS OUT, GND, VS	$V_{ESD}$	-2	2	kV	HBM <sup>3)</sup>
			-6	6		

1) Not subject to production test, specified by design

2) Maximum reachable current may be smaller depending on current limitation level

3) ESD susceptibility, HBM according to EIA/JESD22-A114-B (1.5 kΩ, 100 pF)

*Note: Stresses above the ones listed here may cause permanent damage to the device. Exposure to absolute maximum rating conditions for extended periods may affect device reliability.*

*Note: Integrated protection functions are designed to prevent IC destruction under fault conditions described in the data sheet. Fault conditions are considered as “outside” normal operating range. Protection functions are not designed for continuous repetitive operation.*

### Maximum Single Pulse Current

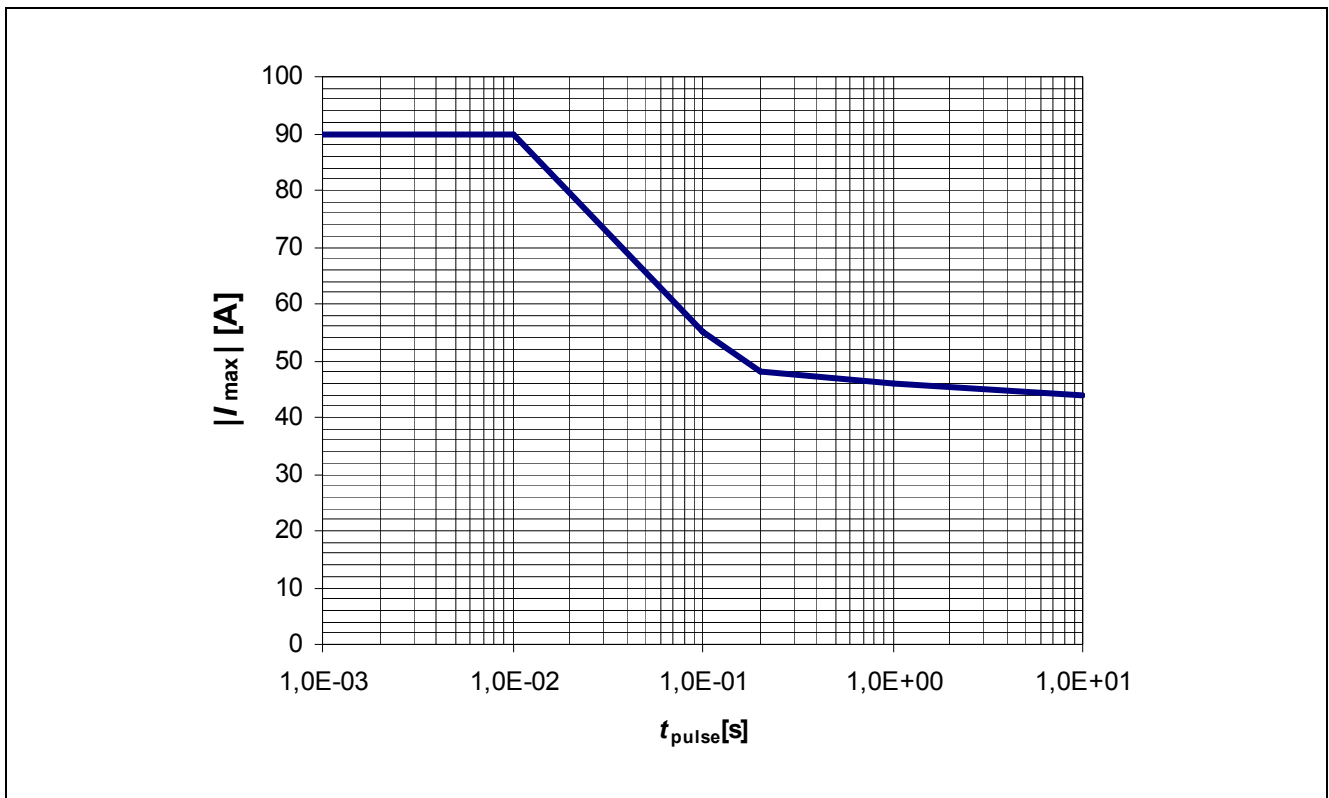

**Figure 4** BTN7960 Maximum Single Pulse Current ( $T_C < 85^\circ\text{C}$ )

This diagram shows the maximum single pulse current that can be driven for a given pulse time  $t_{\text{pulse}}$ . The maximum reachable current may be smaller depending on the current limitation level. Pulse time may be limited due to thermal protection of the device.

## 4.2 Functional Range

Pos.	Parameter	Symbol	Limit Values		Unit	Conditions
			Min.	Max.		
4.2.1	Supply Voltage Range for Nominal Operation	$V_{S(nom)}$	8	18	V	–
4.2.2	Extended Supply Voltage Range for Operation	$V_{S(ext)}$	5.5	28	V	Parameter Deviations possible
4.2.3	Junction Temperature	$T_j$	-40	150	°C	–

Note: Within the functional or operating range, the IC operates as described in the circuit description. The electrical characteristics are specified within the conditions given in the Electrical Characteristics table.

## 4.3 Thermal Resistance

Pos.	Parameter	Symbol	Limit Values			Unit	Conditions
			Min.	Typ.	Max.		
4.3.1	Thermal Resistance Junction-Case, Low Side Switch <sup>1)</sup> $R_{thjC(LS)} = \Delta T_{j(LS)} / P_{v(LS)}$	$R_{thjC(LS)}$	–	1.3	1.8	K/W	–
4.3.2	Thermal Resistance Junction-Case, High Side Switch <sup>1)</sup> $R_{thjC(HS)} = \Delta T_{j(HS)} / P_{v(HS)}$	$R_{thjC(HS)}$	–	0.6	0.9	K/W	–
4.3.3	Thermal Resistance Junction-Case, both Switches <sup>1)</sup> $R_{thjC} = \max[\Delta T_{j(HS)}, \Delta T_{j(LS)}] / (P_{v(HS)} + P_{v(LS)})$	$R_{thjC}$	–	0.7	1.0	K/W	–
4.3.4	Thermal Resistance Junction-Ambient <sup>1)</sup>	$R_{thJA}$	–	20	–	K/W	<sup>2)</sup>

1) Not subject to production test, specified by design

2) Specified  $R_{thJA}$  value is according to Jedec JESD51-2,-5,-7 at natural convection on FR4 2s2p board; The Product (chip+package) was simulated on a 76.2 x 114.3 x 1.5 mm board with 2 inner copper layers (2 x 70 µm Cu, 2 x 35 µm Cu).



## 5 Block Description and Characteristics

### 5.1 Supply Characteristics

$V_S = 8\text{ V to }18\text{ V}$ ,  $T_j = -40\text{ }^\circ\text{C to }+150\text{ }^\circ\text{C}$ ,  $I_L = 0\text{ A}$ , all voltages with respect to ground, positive current flowing into pin (unless otherwise specified)

Pos.	Parameter	Symbol	Limit Values			Unit	Conditions
			Min.	Typ.	Max.		
<b>General</b>							
5.1.1	Supply Current	$I_{VS(on)}$	–	2	3	mA	$V_{INH} = 5\text{ V}$ $V_{IN} = 0\text{ V or }5\text{ V}$ $R_{SR} = 0\ \Omega$ DC-mode normal operation (no fault condition)
5.1.2	Quiescent Current	$I_{VS(off)}$	–	7	12	$\mu\text{A}$	$V_{INH} = 0\text{ V}$ $V_{IN} = 0\text{ V or }5\text{ V}$ $T_j < 85\text{ }^\circ\text{C}$
			–	–	65	$\mu\text{A}$	$V_{INH} = 0\text{ V}$ $V_{IN} = 0\text{ V or }5\text{ V}$

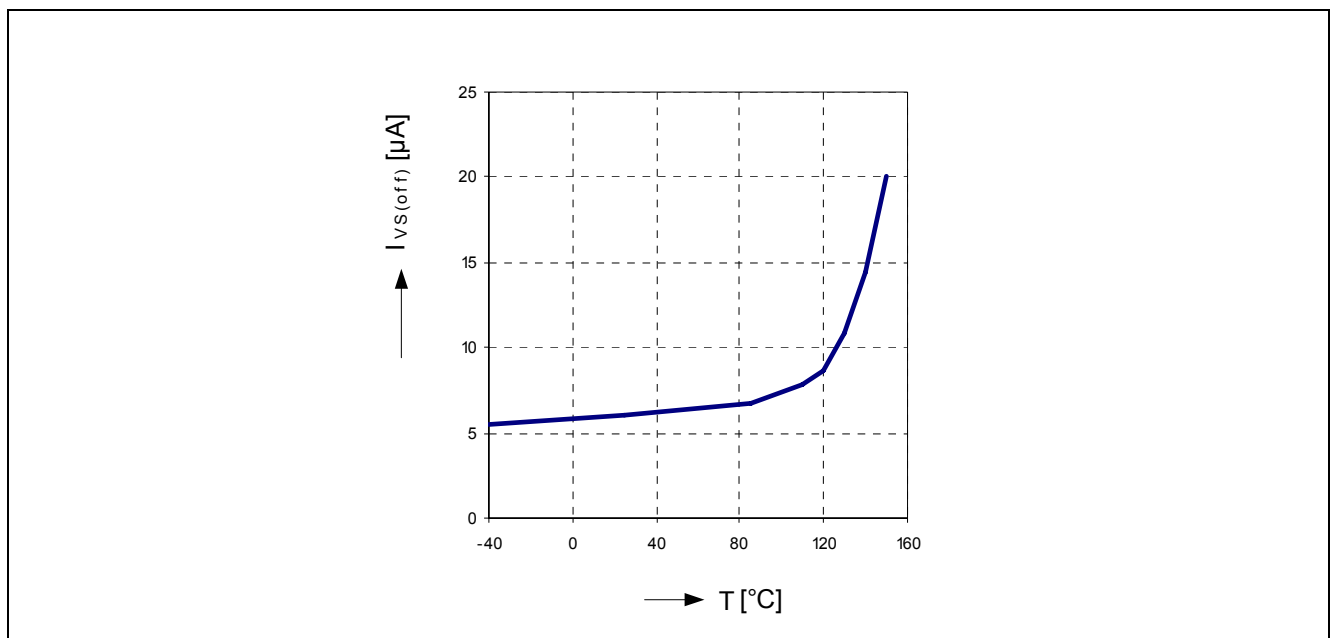

Figure 5 Typical Quiescent Current vs. Junction Temperature

## 5.2 Power Stages

The power stages of the BTN7960 consist of a p-channel vertical DMOS transistor for the high side switch and a n-channel vertical DMOS transistor for the low side switch. All protection and diagnostic functions are located in a separate top chip. Both switches can be operated up to 25 kHz, allowing active freewheeling and thus minimizing power dissipation in the forward operation of the integrated diodes.

The on state resistance  $R_{ON}$  is dependent on the supply voltage  $V_S$  as well as on the junction temperature  $T_j$ . The typical on state resistance characteristics are shown in [Figure 6](#).

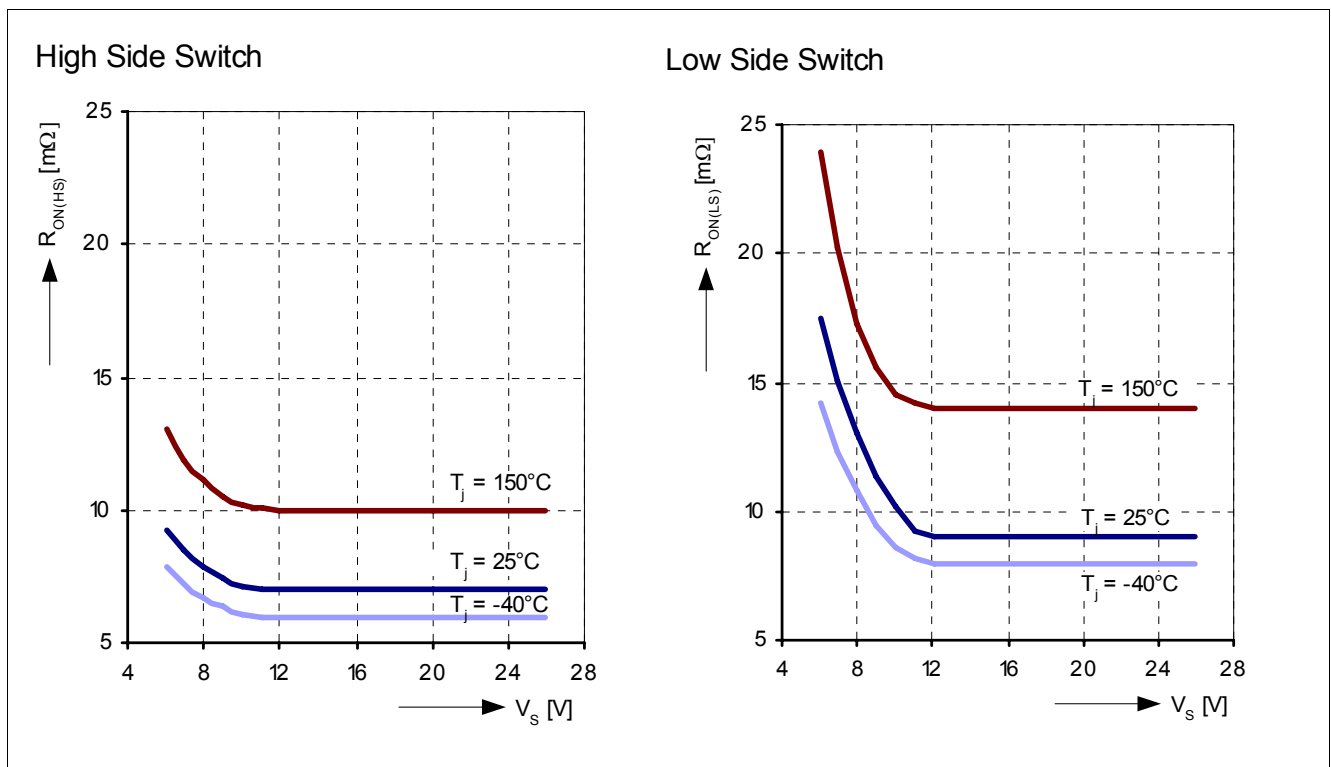

Figure 6 Typical ON State Resistance vs. Supply Voltage (BTN7960B)



## 5.2.2 Switching Times

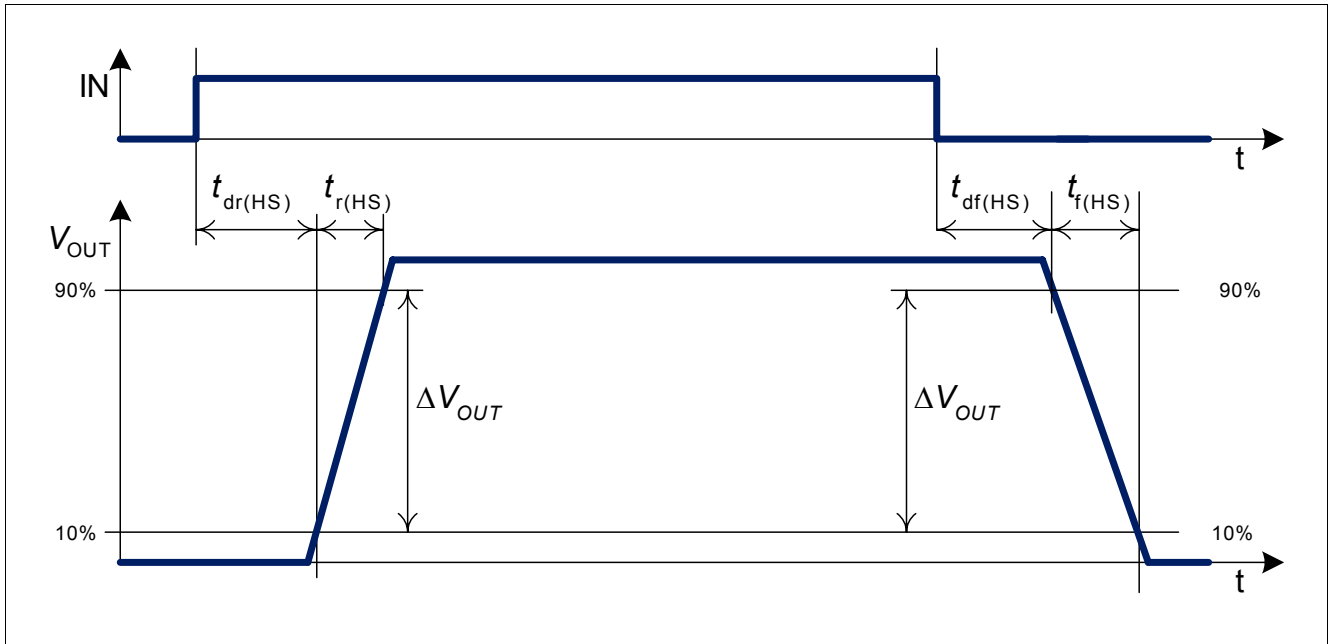

Figure 7 Definition of switching times high side ( $R_{load}$  to GND)

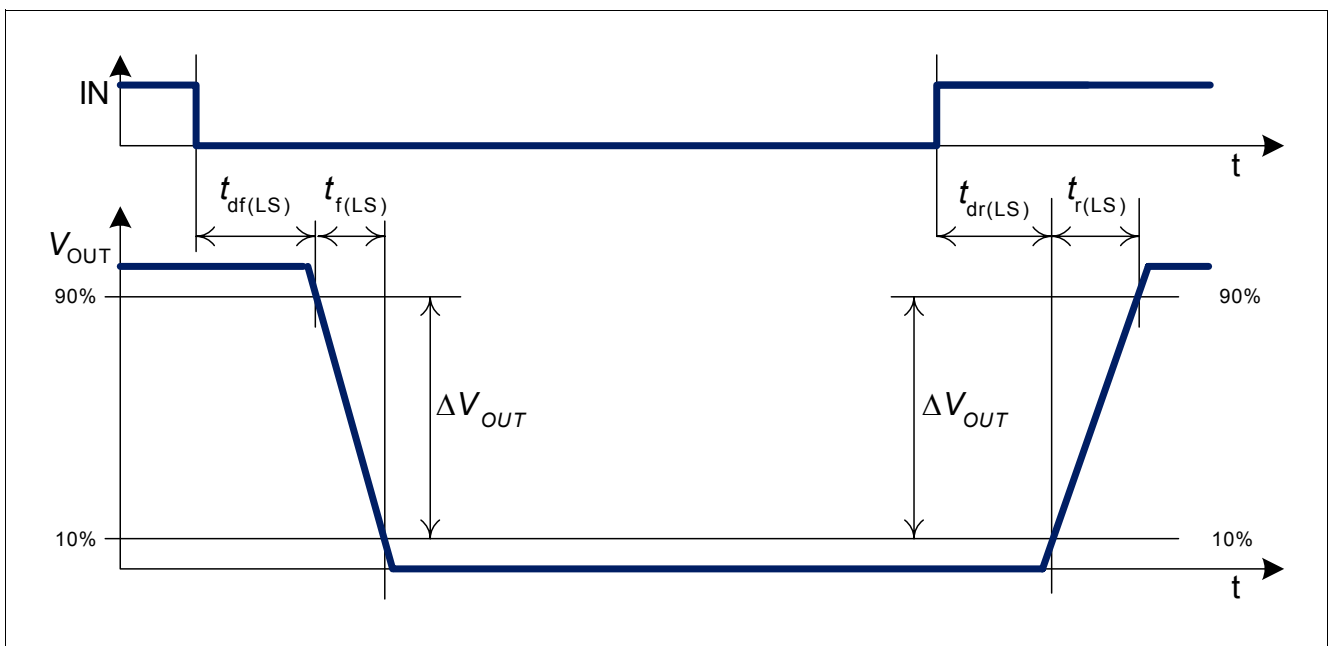

Figure 8 Definition of switching times low side ( $R_{load}$  to VS)

Due to the timing differences for the rising and the falling edge there will be a slight difference between the length of the input pulse and the length of the output pulse. It can be calculated using the following formulas:

- $\Delta t_{HS} = (t_{dr(HS)} + 0.5 t_{r(HS)}) - (t_{df(HS)} + 0.5 t_{f(HS)})$
- $\Delta t_{LS} = (t_{df(LS)} + 0.5 t_{r(LS)}) - (t_{dr(LS)} + 0.5 t_{f(LS)})$

### 5.2.3 Power Stages - Dynamic Characteristics

$V_S = 13.5\text{ V}$ ,  $T_j = -40\text{ °C}$  to  $+150\text{ °C}$ ,  $R_{load} = 2\ \Omega$ , all voltages with respect to ground, positive current flowing into pin (unless otherwise specified)

Pos.	Parameter	Symbol	Limit Values			Unit	Conditions
			Min.	Typ.	Max.		
<b>High Side Switch Dynamic Characteristics</b>							
5.2.7	Rise-Time of HS	$t_{r(HS)}$	0.5 – 2	1 2 5	1.6 – 11	$\mu\text{s}$	$R_{SR} = 0\ \Omega$ $R_{SR} = 5.1\ \text{k}\Omega$ $R_{SR} = 51\ \text{k}\Omega$
5.2.8	Slew Rate HS on <sup>1)</sup>	$\Delta V_{OUT}/t_{r(HS)}$	6.8 – 1	10.8 5.4 2.2	21.6 – 5.4	$\text{V}/\mu\text{s}$	$R_{SR} = 0\ \Omega$ $R_{SR} = 5.1\ \text{k}\Omega$ $R_{SR} = 51\ \text{k}\Omega$
5.2.9	Switch on Delay Time HS	$t_{dr(HS)}$	1.5 – 5	3.1 4.4 14	4.5 – 25	$\mu\text{s}$	$R_{SR} = 0\ \Omega$ $R_{SR} = 5.1\ \text{k}\Omega$ $R_{SR} = 51\ \text{k}\Omega$
5.2.10	Fall-Time of HS	$t_{f(HS)}$	0.5 – 2	1 2 5	1.6 – 11	$\mu\text{s}$	$R_{SR} = 0\ \Omega$ $R_{SR} = 5.1\ \text{k}\Omega$ $R_{SR} = 51\ \text{k}\Omega$
5.2.11	Slew Rate HS off <sup>1)</sup>	$-\Delta V_{OUT}/t_{f(HS)}$	6.8 – 1	10.8 5.4 2.2	21.6 – 5.4	$\text{V}/\mu\text{s}$	$R_{SR} = 0\ \Omega$ $R_{SR} = 5.1\ \text{k}\Omega$ $R_{SR} = 51\ \text{k}\Omega$
5.2.12	Switch off Delay Time HS	$t_{df(HS)}$	1 – 3	2.4 3.4 10	3 – 17	$\mu\text{s}$	$R_{SR} = 0\ \Omega$ $R_{SR} = 5.1\ \text{k}\Omega$ $R_{SR} = 51\ \text{k}\Omega$

1) Not subject to production test, calculated value;  $|\Delta V_{OUT}|/t_{r(HS)}$  or  $|\Delta V_{OUT}|/t_{f(HS)}$

Block Description and Characteristics

$V_S = 13.5\text{ V}$ ,  $T_j = -40\text{ °C}$  to  $+150\text{ °C}$ ,  $R_{load} = 2\ \Omega$ , all voltages with respect to ground, positive current flowing into pin (unless otherwise specified)

Pos.	Parameter	Symbol	Limit Values			Unit	Conditions
			Min.	Typ.	Max.		
<b>Low Side Switch Dynamic Characteristics</b>							
5.2.13	Rise-Time of LS	$t_{r(LS)}$	0.4 – 2	0.9 2 5	1.4 – 11	$\mu\text{s}$	$R_{SR} = 0\ \Omega$ $R_{SR} = 5.1\ \text{k}\Omega$ $R_{SR} = 51\ \text{k}\Omega$
5.2.14	Slew Rate LS switch off <sup>1)</sup>	$\Delta V_{OUT}/t_{r(LS)}$	7.7 – 1	12 5.4 2.2	27 – 5.4	$\text{V}/\mu\text{s}$	$R_{SR} = 0\ \Omega$ $R_{SR} = 5.1\ \text{k}\Omega$ $R_{SR} = 51\ \text{k}\Omega$
5.2.15	Switch off Delay Time LS	$t_{dr(LS)}$	0.6 – 2	1.3 2.2 5	2 – 11	$\mu\text{s}$	$R_{SR} = 0\ \Omega$ $R_{SR} = 5.1\ \text{k}\Omega$ $R_{SR} = 51\ \text{k}\Omega$
5.2.16	Fall-Time of LS	$t_{f(LS)}$	0.5 – 2	1 2 5	1.5 – 11	$\mu\text{s}$	$R_{SR} = 0\ \Omega$ $R_{SR} = 5.1\ \text{k}\Omega$ $R_{SR} = 51\ \text{k}\Omega$
5.2.17	Slew Rate LS switch on <sup>1)</sup>	$-\Delta V_{OUT}/t_{f(LS)}$	7.2 – 1	10.8 5.4 2.2	21.6 – 5.4	$\text{V}/\mu\text{s}$	$R_{SR} = 0\ \Omega$ $R_{SR} = 5.1\ \text{k}\Omega$ $R_{SR} = 51\ \text{k}\Omega$
5.2.18	Switch on Delay Time LS	$t_{df(LS)}$	2 – 5	4 5.6 15	5 – 25	$\mu\text{s}$	$R_{SR} = 0\ \Omega$ $R_{SR} = 5.1\ \text{k}\Omega$ $R_{SR} = 51\ \text{k}\Omega$

1) Not subject to production test, calculated value;  $|\Delta V_{OUT}|/t_{r(LS)}$  or  $|\Delta V_{OUT}|/t_{f(LS)}$

### 5.3 Protection Functions

The device provides integrated protection functions. These are designed to prevent IC destruction under fault conditions described in the data sheet. Fault conditions are considered as “outside” normal operating range. Protection functions are not to be used for continuous or repetitive operation, with the exception of the current limitation ([Chapter 5.3.4](#)). In a fault condition the BTN7960 will apply the highest slew rate possible independent of the connected slew rate resistor. Overvoltage, overtemperature and overcurrent are indicated by a fault current  $I_{IS(LIM)}$  at the IS pin as described in the paragraph “[Status Flag Diagnosis With Current Sense Capability](#)” on [Page 19](#) and [Figure 12](#).

In the following the protection functions are listed in order of their priority. Overvoltage lock out overrides all other error modes.

#### 5.3.1 Overvoltage Lock Out

To assure a high immunity against overvoltages (e.g. load dump conditions) the device shuts the lowside MOSFET off and turns the highside MOSFET on, if the supply voltage is exceeding the over voltage protection level  $V_{OV(OFF)}$ . The IC operates in normal mode again with a hysteresis  $V_{OV(HY)}$  if the supply voltage decreases below the switch-on voltage  $V_{OV(ON)}$ . In H-bridge configuration, this behavior of the BTN7960 will lead to freewheeling in highside during over voltage.

#### 5.3.2 Undervoltage Shut Down

To avoid uncontrolled motion of the driven motor at low voltages the device shuts off (output is tri-state), if the supply voltage drops below the switch-off voltage  $V_{UV(OFF)}$ . The IC becomes active again with a hysteresis  $V_{UV(HY)}$  if the supply voltage rises above the switch-on voltage  $V_{UV(ON)}$ .

#### 5.3.3 Overtemperature Protection

The BTN7960 is protected against overtemperature by an integrated temperature sensor. Overtemperature leads to a shut down of both output stages. This state is latched until the device is reset by a low signal with a minimum length of  $t_{reset}$  at the INH pin, provided that its temperature has decreased at least the thermal hysteresis  $\Delta T$  in the meantime.

Repetitive use of the overtemperature protection impacts lifetime.

#### 5.3.4 Current Limitation

The current in the bridge is measured in both switches. As soon as the current in forward direction in one switch (high side or low side) is reaching the limit  $I_{CLX}$ , this switch is deactivated and the other switch is activated for  $t_{CLS}$ . During that time all changes at the IN pin are ignored. However, the INH pin can still be used to switch both MOSFETs off. After  $t_{CLS}$  the switches return to their initial setting. The error signal at the IS pin is reset after  $2 * t_{CLS}$ . Unintentional triggering of the current limitation by short current spikes (e.g. inflicted by EMI coming from the motor) is suppressed by internal filter circuitry. Due to thresholds and reaction delay times of the filter circuitry the effective current limitation level  $I_{CLX}$  depends on the slew rate of the load current  $di/dt$  as shown in [Figure 10](#).

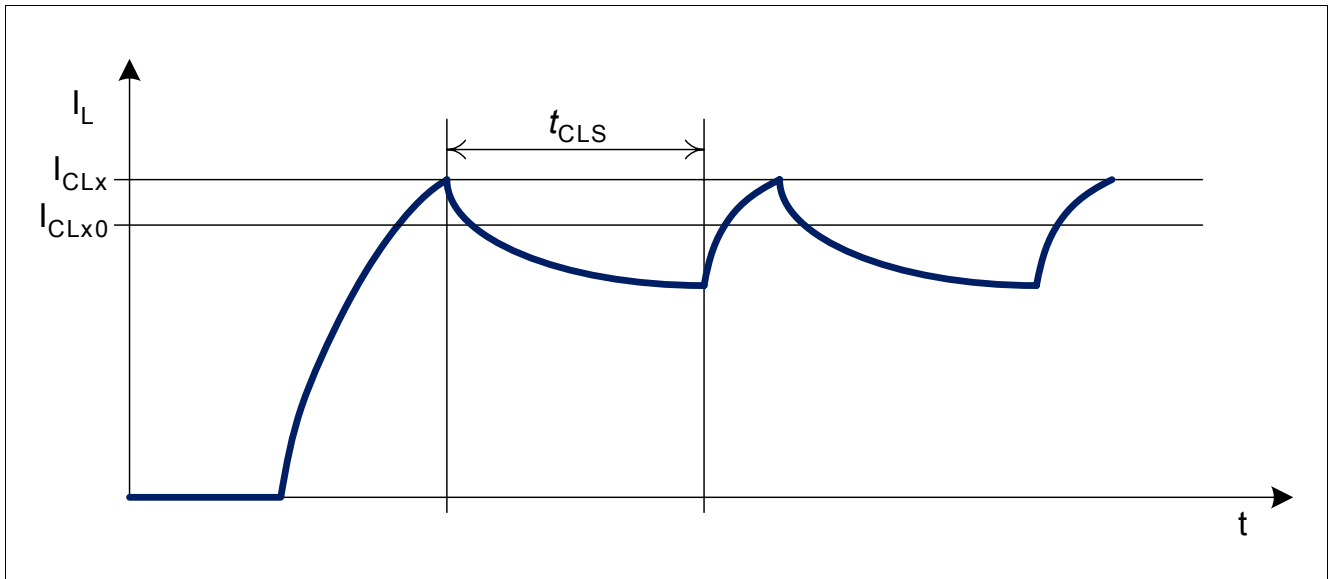

Figure 9 Timing Diagram Current Limitation (Inductive Load)

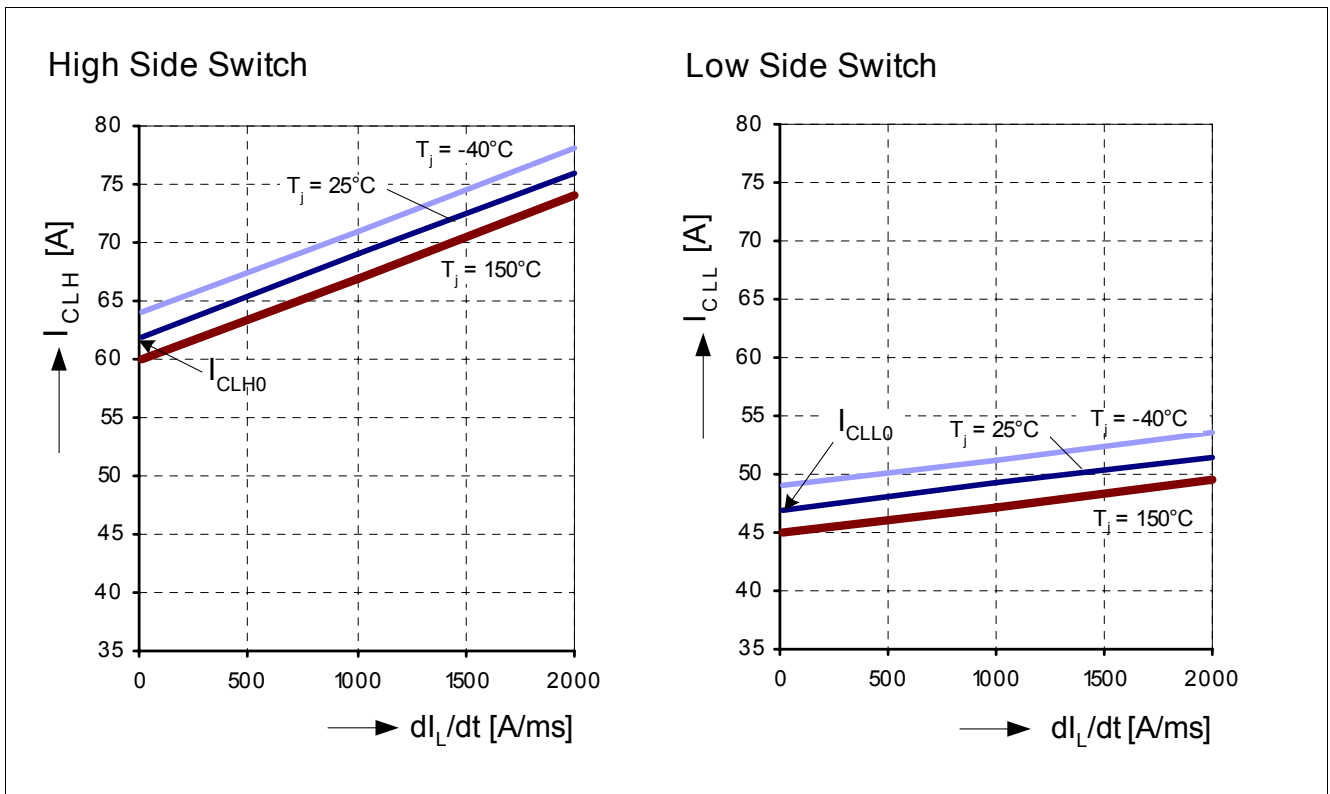

Figure 10 Typical Current Limitation Level vs. Current Slew Rate  $di/dt$



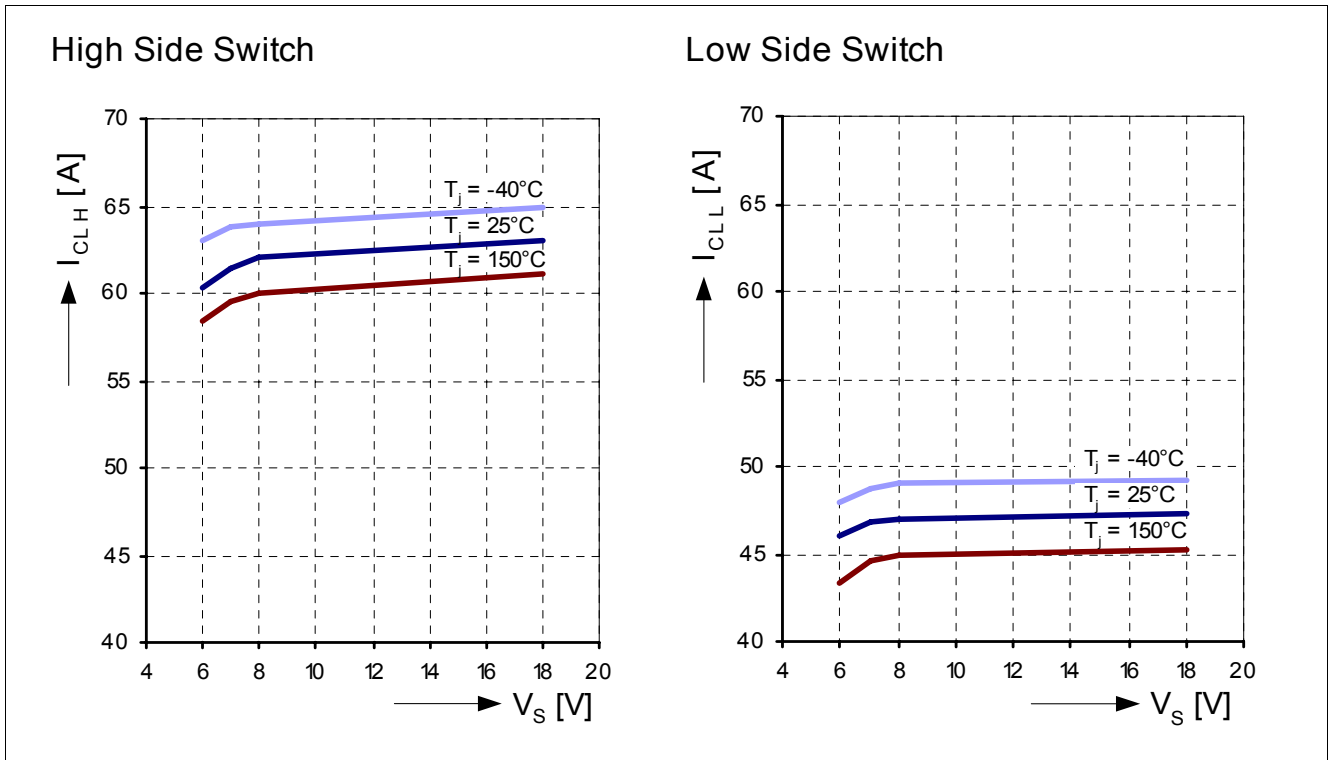

Figure 11 Typical Current Limitation Detection Levels vs. Supply Voltage

In combination with a typical inductive load, such as a motor, this results in a switched mode current limitation. This method of limiting the current has the advantage of greatly reduced power dissipation in the BTN7960 compared to driving the MOSFET in linear mode. Therefore it is possible to use the current limitation for a short time without exceeding the maximum allowed junction temperature (e.g. for limiting the inrush current during motor start up). However, the regular use of the current limitation is allowed as long as the specified maximum junction temperature is not exceeded. Exceeding this temperature can reduce the lifetime of the device.

### 5.3.5 Short Circuit Protection

The device is short circuit protected against

- output short circuit to ground
- output short circuit to supply voltage
- short circuit of load

The short circuit protection is realized by the previously described current limitation in combination with the over-temperature shut down of the device.

### 5.3.6 Electrical Characteristics - Protection Functions

$V_S = 8\text{ V to }18\text{ V}$ ,  $T_j = -40\text{ °C to }+150\text{ °C}$ , all voltages with respect to ground, positive current flowing into pin (unless otherwise specified)

Pos.	Parameter	Symbol	Limit Values			Unit	Conditions
			Min.	Typ.	Max.		
<b>Under Voltage Shut Down</b>							
5.3.1	Switch-ON Voltage	$V_{UV(ON)}$	–	–	5.5	V	$V_S$ increasing
5.3.2	Switch-OFF Voltage	$V_{UV(OFF)}$	4.0	–	5.4	V	$V_S$ decreasing
5.3.3	ON/OFF hysteresis	$V_{UV(HY)}$	–	0.2	–	V	–
<b>Over Voltage Lock Out</b>							
5.3.4	Switch-ON Voltage	$V_{OV(ON)}$	27.8	–	–	V	$V_S$ decreasing
5.3.5	Switch-OFF Voltage	$V_{OV(OFF)}$	28	–	30	V	$V_S$ increasing
5.3.6	ON/OFF hysteresis	$V_{OV(HY)}$	–	0.2	–	V	–
<b>Current Limitation</b>							
5.3.7	Current Limitation Detection level High Side	$I_{CLH0}$	45	62	80	A	$V_S = 13.5\text{ V}$
5.3.8	Current Limitation Detection level Low Side	$I_{CLL0}$	33	47	60	A	$V_S = 13.5\text{ V}$
<b>Current Limitation Timing</b>							
5.3.9	Shut OFF Time for HS and LS	$t_{CLS}$	70	115	210	µs	$V_S = 13.5\text{ V}$
<b>Thermal Shut Down</b>							
5.3.10	Thermal Shut Down Junction Temperature	$T_{jSD}$	155	175	200	°C	–
5.3.11	Thermal Switch ON Junction Temperature	$T_{jSO}$	150	–	190	°C	–
5.3.12	Thermal Hysteresis	$\Delta T$	–	7	–	K	–
5.3.13	Reset Pulse at INH Pin (INH low)	$t_{reset}$	4	–	–	µs	–

## 5.4 Control and Diagnostics

### 5.4.1 Input Circuit

The control inputs IN and INH consist of TTL/CMOS compatible schmitt triggers with hysteresis which control the integrated gate drivers for the MOSFETs. Setting the INH pin to high enables the device. In this condition one of the two power switches is switched on depending on the status of the IN pin. To deactivate both switches, the INH pin has to be set to low. No external driver is needed. The BTN7960 can be interfaced directly to a microcontroller, as long as the maximum ratings in [Chapter 4.1](#) are not exceeded.

### 5.4.2 Dead Time Generation

In bridge applications it has to be assured that the highside and lowside MOSFET are not conducting at the same time, connecting directly the battery voltage to GND. This is assured by a circuit in the driver IC, generating a so called dead time between switching off one MOSFET and switching on the other. The dead time generated in the driver IC is automatically adjusted to the selected slew rate.

### 5.4.3 Adjustable Slew Rate

In order to optimize electromagnetic emission, the switching speed of the MOSFETs is adjustable by an external resistor. The slew rate pin SR allows the user to optimize the balance between emission and power dissipation within his own application by connecting an external resistor  $R_{SR}$  to GND.

### 5.4.4 Status Flag Diagnosis With Current Sense Capability

The status pin IS is used as a combined current sense and error flag output. In normal operation (current sense mode), a current source is connected to the status pin, which delivers a current proportional to the forward load current flowing through the active high side switch. If the high side switch is inactive or the current is flowing in the reverse direction no current will be driven except for a marginal leakage current  $I_{IS(LK)}$ . The external resistor  $R_{IS}$  determines the voltage per output current. E.g. with the nominal value of **8.5k** for the current sense ratio  $k_{ILIS} = I_L / I_{IS}$ , a resistor value of  $R_{IS} = 1 \text{ k}\Omega$  leads to  $V_{IS} = (I_L / 8.5 \text{ A})V$ . In case of a fault condition the status output is connected to a current source which is independent of the load current and provides  $I_{IS(lim)}$ . The maximum voltage at the IS pin is determined by the choice of the external resistor and the supply voltage. In case of current limitation the  $I_{IS(lim)}$  is activated for  $2 * t_{CLS}$ .

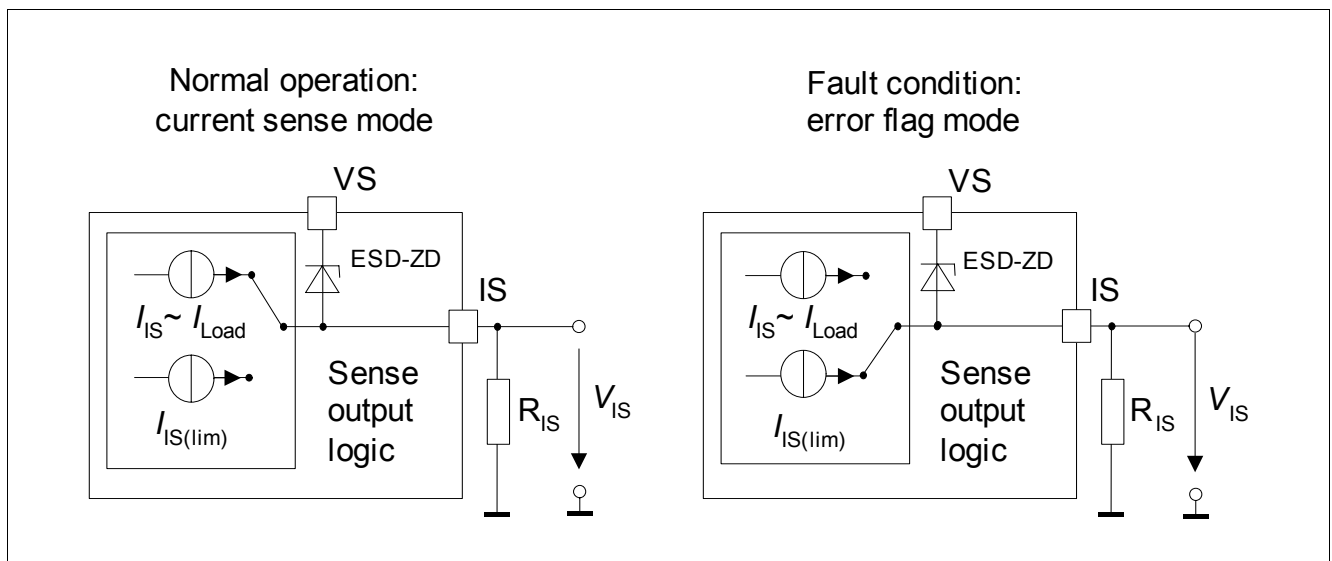

Figure 12 Sense Current and Fault Current

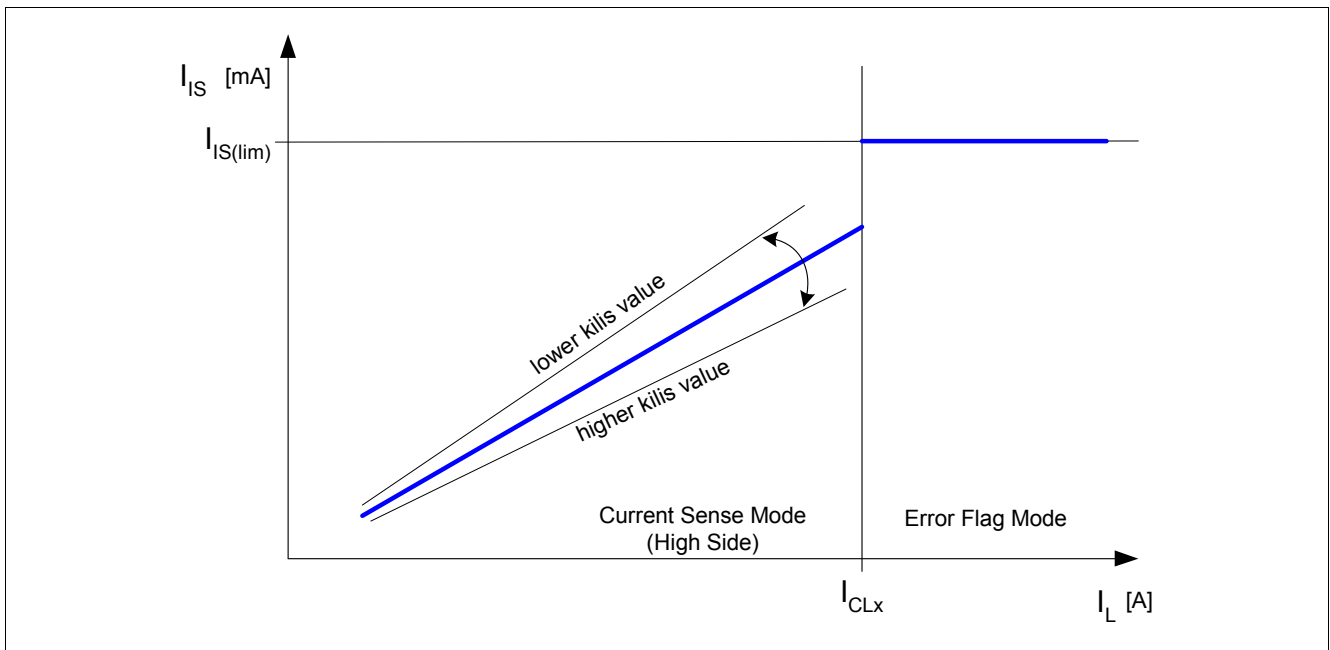

Figure 13 Sense Current vs. Load Current

### 5.4.5 Truth Table

Device State	Inputs		Outputs			Mode
	INH	IN	HSS	LSS	IS	
Normal Operation	0	X	OFF	OFF	0	Stand-by mode
	1	0	OFF	ON	0	LSS active
	1	1	ON	OFF	CS	HSS active
Over-Voltage (OV)	X	X	ON	OFF	1	Shut-down of LSS, HSS activated, error detected
Under-Voltage (UV)	X	X	OFF	OFF	0	UV lockout
Overtemperature or Short Circuit of HSS or LSS	0	X	OFF	OFF	0	Stand-by mode, reset of latch
	1	X	OFF	OFF	1	Shut-down with latch, error detected
Current Limitation Mode	1	1	OFF	ON	1	Switched mode, error detected <sup>1)</sup>
	1	0	ON	OFF	1	Switched mode, error detected <sup>1)</sup>

1) Will return to normal operation after  $t_{CLS}$ ; Error signal is reset after  $2 \cdot t_{CLS}$  (see [Chapter 5.3.4](#))

Inputs	Switches	Status Flag IS
0 = Logic LOW	OFF = switched off	CS = Current sense mode
1 = Logic HIGH	ON = switched on	1 = Logic HIGH (error)
X = 0 or 1		

### 5.4.6 Electrical Characteristics - Control and Diagnostics

$V_S = 8\text{ V to }18\text{ V}$ ,  $T_j = -40\text{ °C to }+150\text{ °C}$ , all voltages with respect to ground, positive current flowing into pin (unless otherwise specified)

Pos.	Parameter	Symbol	Limit Values			Unit	Conditions
			Min.	Typ.	Max.		
<b>Control Inputs (IN and INH)</b>							
5.4.1	High level Voltage INH, IN	$V_{IN(H)}$ $V_{IN(H)}$	–	1.75 1.6	2.15 2	V	–
5.4.2	Low level Voltage INH, IN	$V_{IN(L)}$ $V_{IN(L)}$	1.1	1.4	–	V	–
5.4.3	Input Voltage hysteresis	$V_{IN(HY)}$ $V_{IN(HY)}$	–	350 200	–	mV	–
5.4.4	Input Current high level	$I_{IN(H)}$ $I_{IN(H)}$	–	30	150	μA	$V_{IN} = V_{INH} = 5.3\text{ V}$
5.4.5	Input Current low level	$I_{IN(L)}$ $I_{IN(L)}$	–	25	125	μA	$V_{IN} = V_{INH} = 0.4\text{ V}$
<b>Current Sense</b>							
5.4.6	Current Sense ratio in static on-condition $k_{ILIS} = I_L / I_{IS}$	$k_{ILIS}$	6 5.5 5	8.5 8.5 8.5	11 11.5 12.5	$10^3$	$R_{IS} = 1\text{ k}\Omega$ $I_L = 30\text{ A}$ $I_L = 15\text{ A}$ $I_L = 5\text{ A}$
5.4.7	Maximum analog Sense Current, Sense Current in fault Condition	$I_{IS(lim)}$	4	5	6.5	mA	$V_S = 13.5\text{ V}$ $R_{IS} = 1\text{ k}\Omega$
5.4.8	Isense Leakage current	$I_{ISL}$	–	–	1	μA	$V_{IN} = 0\text{ V}$ or $V_{INH} = 0\text{ V}$
5.4.9	Isense Leakage current, active high side switch	$I_{ISH}$	–	1	80	μA	$V_{IN} = V_{INH} = 5\text{ V}$ $I_L = 0\text{ A}$

## 6 Application Information

Note: The following information is given as a hint for the implementation of the device only and shall not be regarded as a description or warranty of a certain functionality, condition or quality of the device.

### 6.1 Application Example

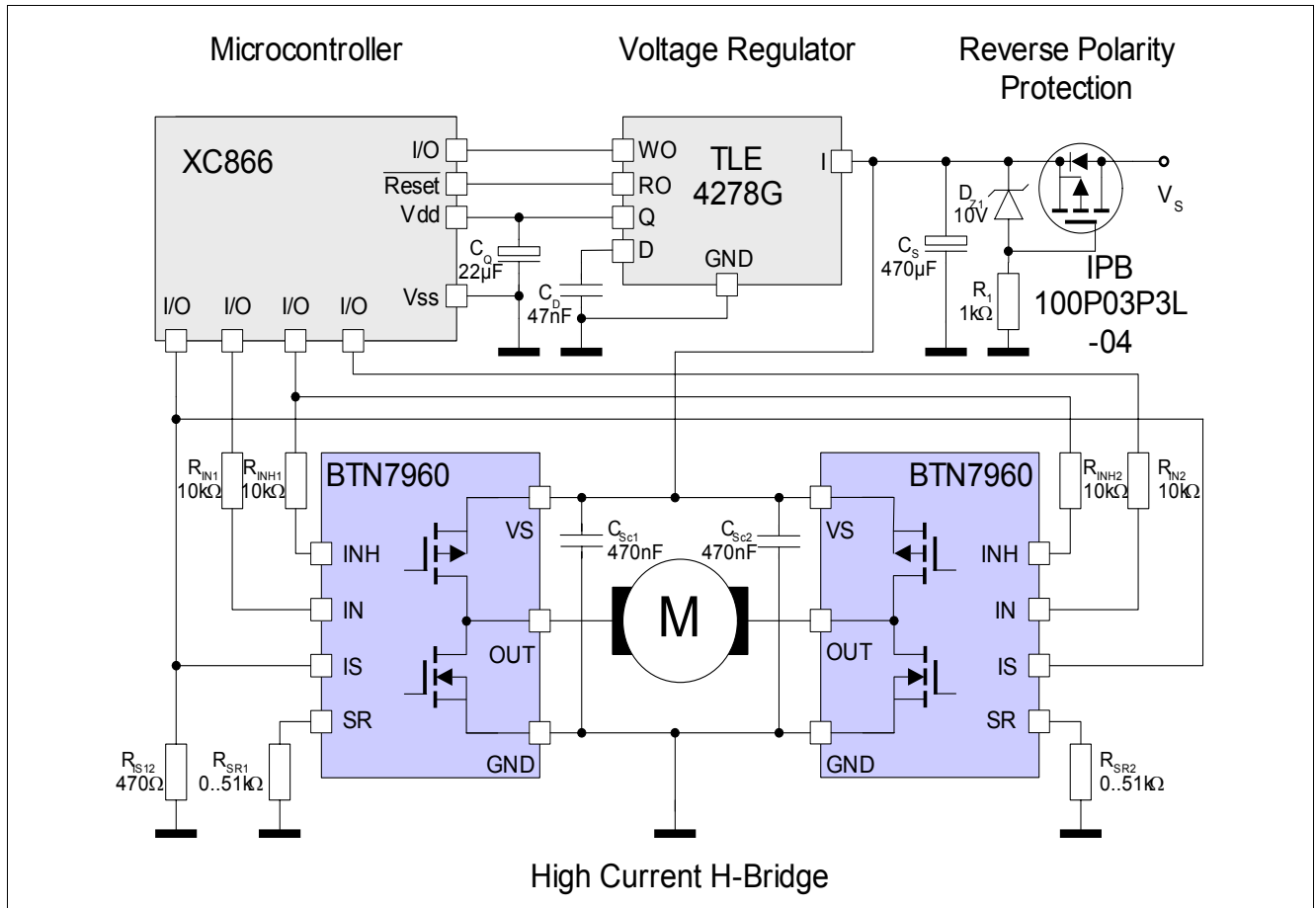

Figure 14 Application Example: H-Bridge with two BTN7960

Note: This is a simplified example of an application circuit. The function must be verified in the real application.

### 6.2 Layout Considerations

Due to the fast switching times for high currents, special care has to be taken to the PCB layout. Stray inductances have to be minimized in the power bridge design as it is necessary in all switched high power bridges. The BTN7960 has no separate pin for power ground and logic ground. Therefore it is recommended to assure that the offset between the ground connection of the slew rate resistor, the current sense resistor and ground pin of the device (GND / pin 1) is minimized. If the BTN7960 is used in a H-bridge or B6 bridge design, the voltage offset between the GND pins of the different devices should be small as well.

A ceramic capacitor from VS to GND close to each device is recommended to provide current for the switching phase via a low inductance path and therefore reducing noise and ground bounce. A reasonable value for this capacitor would be about 470 nF.

The digital inputs need to be protected from excess currents (e.g. caused by induced voltage spikes) by series resistors in the range of 10 k $\Omega$ .



## 7 Package Outlines

### 7.1 PG-TO263-7-1

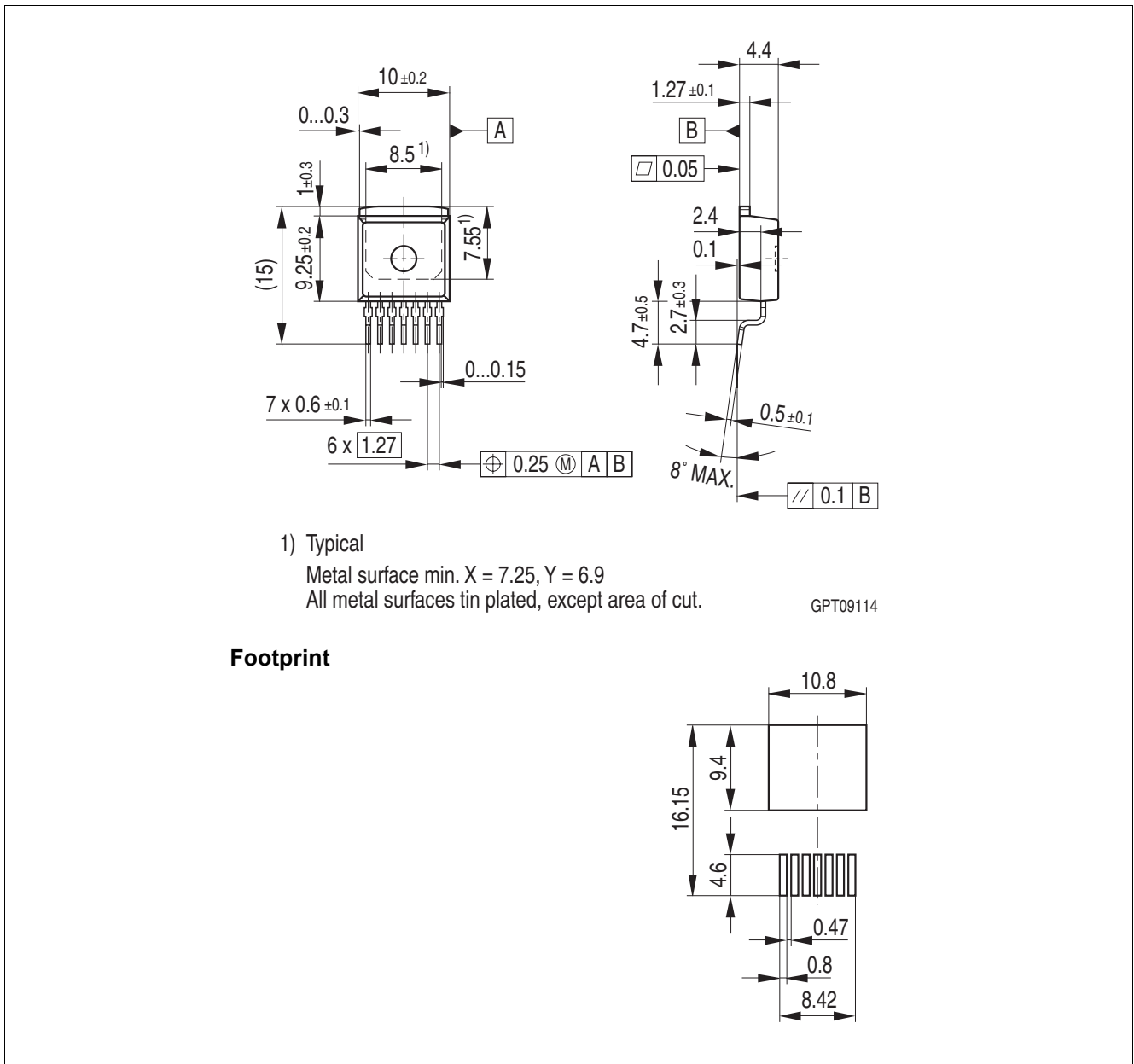

Figure 16 PG-TO263-7-1 (Plastic Green Transistor Single Outline Package)

#### Green Product (RoHS compliant)

To meet the world-wide customer requirements for environmentally friendly products and to be compliant with government regulations the device is available as a green product. Green products are RoHS-Compliant (i.e Pb-free finish on leads and suitable for Pb-free soldering according to IPC/JEDEC J-STD-020).

For further information on alternative packages, please visit our website:

<http://www.infineon.com/packages>.

Dimensions in mm



7.2 PG-TO220-7-11

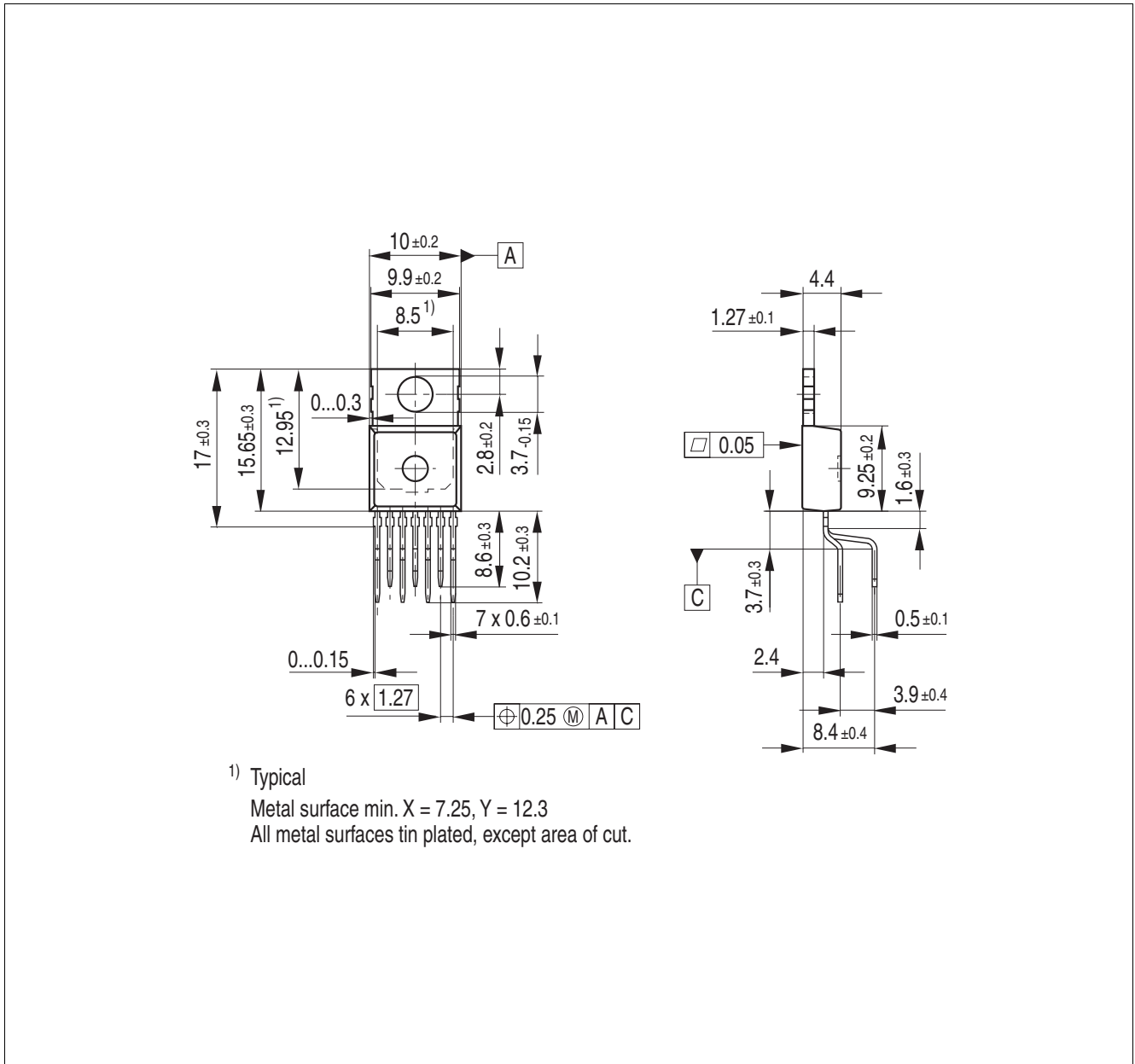

Figure 17 PG-TO220-7-11 (Plastic Green Transistor Single Outline Package)

**Green Product (RoHS compliant)**

To meet the world-wide customer requirements for environmentally friendly products and to be compliant with government regulations the device is available as a green product. Green products are RoHS-Compliant (i.e Pb-free finish on leads and suitable for Pb-free soldering according to IPC/JEDEC J-STD-020).

For further information on alternative packages, please visit our website:  
<http://www.infineon.com/packages>.

Dimensions in mm

7.3 PG-TO220-7-12

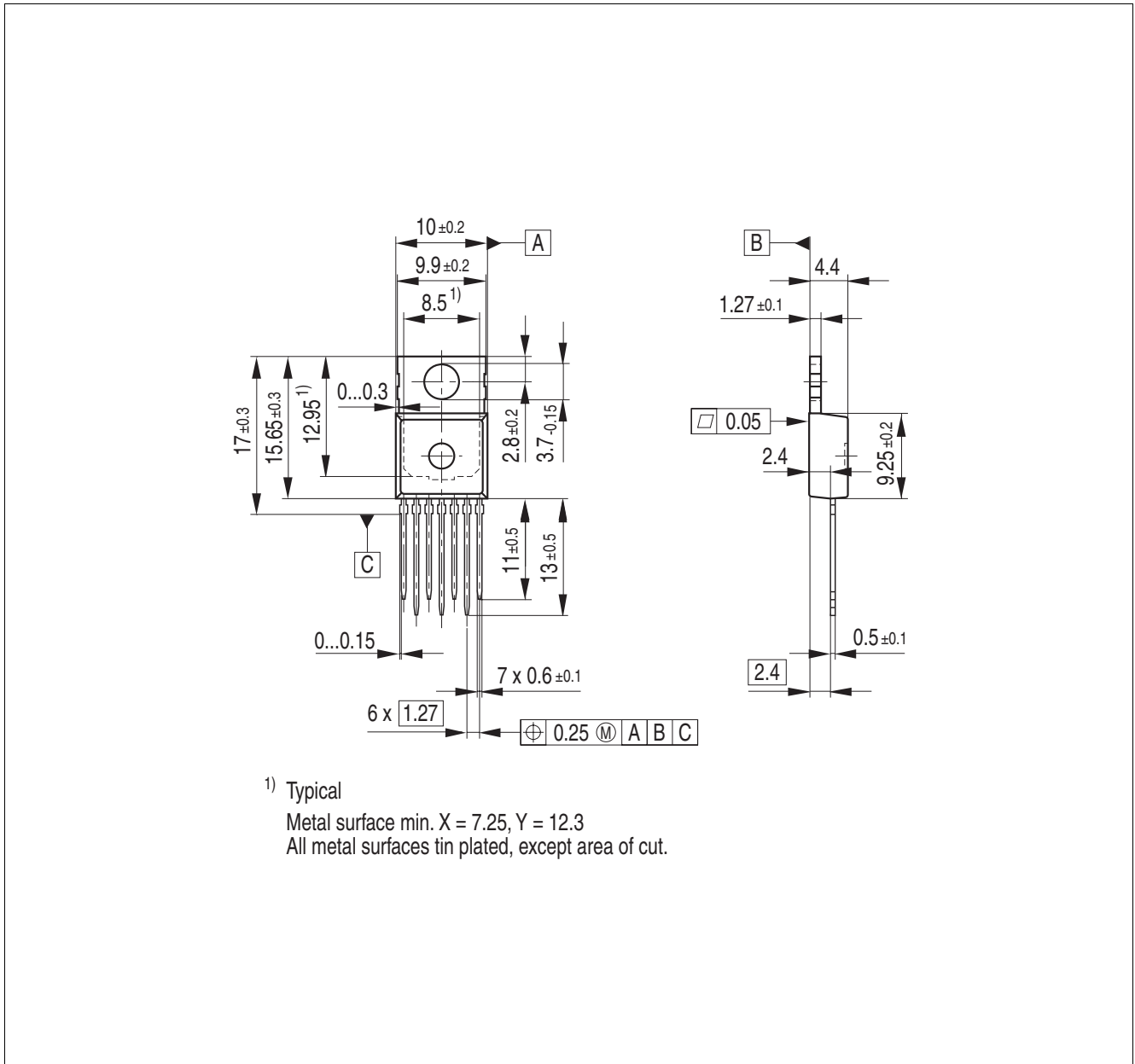

Figure 18 PG-TO220-7-12 (Plastic Transistor Single Outline Package)

Green Product (RoHS compliant)

To meet the world-wide customer requirements for environmentally friendly products and to be compliant with government regulations the device is available as a green product. Green products are RoHS-Compliant (i.e Pb-free finish on leads and suitable for Pb-free soldering according to IPC/JEDEC J-STD-020).

For further information on alternative packages, please visit our website:  
<http://www.infineon.com/packages>.

Dimensions in mm

## 8 Revision History

Revision	Date	Changes
1.1	2007-11-21	New packages added;
1.0	2007-11-06	Initial version Data Sheet

**Edition 2007-11-21**

**Published by  
Infineon Technologies AG  
81726 Munich, Germany**

**© 2007 Infineon Technologies AG  
All Rights Reserved.**

### **Legal Disclaimer**

The information given in this document shall in no event be regarded as a guarantee of conditions or characteristics. With respect to any examples or hints given herein, any typical values stated herein and/or any information regarding the application of the device, Infineon Technologies hereby disclaims any and all warranties and liabilities of any kind, including without limitation, warranties of non-infringement of intellectual property rights of any third party.

### **Information**

For further information on technology, delivery terms and conditions and prices, please contact the nearest Infineon Technologies Office ([www.infineon.com](http://www.infineon.com)).

### **Warnings**

Due to technical requirements, components may contain dangerous substances. For information on the types in question, please contact the nearest Infineon Technologies Office.

Infineon Technologies components may be used in life-support devices or systems only with the express written approval of Infineon Technologies, if a failure of such components can reasonably be expected to cause the failure of that life-support device or system or to affect the safety or effectiveness of that device or system. Life support devices or systems are intended to be implanted in the human body or to support and/or maintain and sustain and/or protect human life. If they fail, it is reasonable to assume that the health of the user or other persons may be endangered.